



INSTRUCTION MANUAL



PF Rotational Peeling Tool

for PE/PP pipes 20-63 mm
for PE/PP pipes 20-125 mm

Table of contents

1.	Safety	4
1.1	General safety guidelines for tools	4
1.2	Specific safety guidelines for the Rotational Peeling Tool.....	5
1.3	Explanation of symbols	5
1.3.1	General symbols	5
1.3.2	Mandatory symbols	5
1.3.3	Prohibition symbols	5
1.3.4	Warning symbols.....	5
2.	Introduction	6
2.1	Scope of application	6
2.2	Maintenance and service.....	6
2.3	Handling and maintenance.....	6
2.4	Disposal	6
3.	Scope of delivery	7
4.	Technical data	8
4.1	Rotational Peeling Tool 20-63 mm.....	8
4.2	Rotational Peeling Tool 20-125 mm.....	8
5.	Spare parts	9
5.1	Rotational Peeling Tool 20-63 mm.....	9
5.2	Rotational Peeling Tool 20-125 mm.....	10
6.	Overview	11
6.1	Rotational Peeling Tool 20-63 mm.....	11
6.2	Rotational Peeling Tool 20-125 mm.....	12
6.3	Special features.....	12
7.	Scraping	13
7.1	Preparation	13
7.2	Preparation and adjustment.....	14
7.2.1	Rotational Peeling Tool 20-125 mm	16
7.3	Peeler blade adjustment.....	17
7.4	Mounting the Rotational Peeling Tool.....	20
7.4.1	Further course of action for the scraping of pipe ends	23
7.4.2	Further course of action for the scraping of saddle installation areas	23
7.5	Scraping the pipe	25
7.6	Taking the rotational peeling tool off	25
7.7	Additional notes	25
8.	Changing the peeler blade	26

1. Safety

The basic condition for safely handling and a hassle-free operation of the product is the knowledge about the fundamental safety guidelines and safety regulations. This instruction manual contains important information on how to handle the tool safely. Everyone working with this equipment shall read and understand these instructions. These instructions shall be read and implemented in accordance with the relevant standards, workplace health and safety legislation, installation instructions, Codes of Practice and technical connection guideline in force in your country.

1.1 General safety guidelines for tools

- a) Read and make sure you understand all safety guidelines and instructions. Failure to follow the safety guidelines and instructions can lead to electric shock, fire and/or serious injury.
- b) Keep these safety guidelines and instructions for future use.

2) Safety in the work area

- a) Keep your work area clean and well lit. Working in cluttered or dark areas can easily lead to accidents. Prevent the tool from unintentional movement or dropping and assume a secure foothold.

3) Personal safety

- a) Stay alert! Watch what you are doing and use common sense when operating a tool.
- b) Use personal protective equipment and always wear eye protection. The use of protective equipment such as a dust mask, non-skid safety shoes, a hard hat or hearing protection, depending on the tool and its use will reduce personal injuries.
- c) Wear appropriate clothing. Do not wear loose clothing or jewellery. Keep your hair, clothing and gloves away from moving parts. Loose clothes, jewellery or long hair can get caught by moving parts.

4) Tool usage and care

- a) Keep cutting tools sharp and clean. Properly maintained cutting tools with sharp and clean blades do not get stuck as easily and are easier to handle during operation.
- b) The blade is subject to wear. Store the rotational pipe peeler dry and clean in the transport suitcase.
- c) Keep your tools clean. Follow the servicing instructions and the instructions for changing the tools. Keep oil and grease away from the handles.
- d) Care for your tools. Check for misalignment or binding of moving parts, breakage of parts and any other condition that may affect the operation of the tools. If damaged, have the tool repaired before use. Many accidents are caused by poorly maintained tools.
- e) Use the tool, accessories etc. in accordance with these instructions. Take the working conditions and the work to be performed into account. The use of the tool for applications differing from the application scope could result in a hazardous situation.
- f) The thickness of the peeling must be checked with a suitable measuring instrument on a regular basis.

5) Service

- a) Have your tool repaired only by a qualified technician with identical replacement parts. This will ensure that the safety of the tool is maintained.

1.2 Specific safety guidelines for the Rotational Peeling Tool

1) Personal safety

- a) The operator must have a safe foothold. Working overhead in areas not completely visible (e.g. under a pipe) is prohibited.
- b) Pipes and other workpieces must be firmly clamped or fixed. Poorly clamped or fixed workpieces may hurt you or affect your safe foothold.
- c) The blade is very sharp. This poses a risk of injury. Do not touch the blade.

1.3 Explanation of symbols

This instruction manual can make use of the following symbols:

1.3.1 General symbols



This symbol indicates a general advice.

These advices describe recommended courses of action to enable the user to perform steps quicker and safer. The symbol can also underline certain required precondition or mean that the user must follow certain mandatory steps.

1.3.2 Mandatory symbols



Observe the instructions!

Read the provided documentation thoroughly to prevent applications errors and to work safer and according to the scope of application with the respective product. All users of the product must thoroughly read and understand the provided documentation prior to use.

Reading the documentation thoroughly and completely helps preventing accidents due to improper use and eases the work with the product.

1.3.3 Prohibition symbols



General prohibition symbol!

There is a high risk of injury. Observe the detailed description of the prohibition.

Failure to comply with this prohibition can lead to injury or damage to devices, machines or tools.

1.3.4 Warning symbols



General warning symbol!

This symbol warns of a potentially dangerous situation.

Failure to comply with the warning and advice can lead to injury or damage to goods.



Warning: Sharp elements!

This symbol warns of a potential risk of injury due to pointy and/or sharp items like needles or blades.

Failure to comply with the warning and advice can lead to stabbing or cutting injuries to the hands or other body parts.

2. Introduction

2.1 Scope of application

The rotational peeling tool is meant exclusively for the removal of the oxide layer on polyethylene (PE) pipes as preparation for electrofusion (EF). Additionally it is approved for usage on polypropylene (PP) and cross-linked polyethylene (PE-X) pipes.

The rotational peeling tool can universally be used to peel pipe ends (for welding fittings) and to peel spots on pipes (for welding saddles). By using an optional extension you can also peel saddle outlets and short spigot fittings in the dimensions 32 mm, 40 mm, 50 mm and 63 mm.



Intended use

It is not allowed to use the tool for any application not covered by the above stated terms. Modifying the tool without consulting the manufacturer is forbidden and shall be considered as improper use.

The manufacturer is not liable for use of the Rotational Peeling Tool that falls outside its application scope!

2.2 Maintenance and service

Should the tool fail despite the great care taken in manufacturing and testing it, the necessary repairs should only be carried out by an after-sales service centre authorised by the manufacturer.

Please note that the product is a technically demanding machine for field application. In accordance to the applicable standards the tool is subject to periodical maintenance. The maintenance interval is 12 months, with heavy use shorter intervals are recommended.

During maintenance, the tool will be upgraded to the current technical standard of our devices and you get a 3-month guarantee on function for the maintained tool.

The maintenance and the related checks are important for your safety and the continuous working reliability and safety of the tool. Therefore, the maintenance and all necessary repairs, have to be carried out by the manufacturer or an authorised service point.

For further information about our after-sales service centres please contact:

PF-Schweißtechnologie GmbH
Karl-Bröger-Str.10
DE-36304 Alsfeld
Germany

Tel.: +49-6631-9652-0
Fax: +49-6631-9652-52
E-Mail: info@pfs-gmbh.com
Web: www.pfs-gmbh.com

In all correspondence, please provide the serial number (S/N) as shown on the type plate of the tool.

2.3 Handling and maintenance

To achieve an optimum work results the tool has to be handled with care and maintained frequently. Pollution by sand and dirt has to be avoided or, if necessary, removed with a soft cloth or a Q-tip.

2.4 Disposal

The rotational peeling tool must be disposed of in an environment-friendly way sorted by materials.

3. Scope of delivery

4_4200_001	Rotational Peeling Tool 20-63 mm		Enclosed
	1 x	Instruction manual	GB267
	1 x	Rotational Peeling Tool 20-63 mm	
	1 x	Hex key screwdriver SW4/SW2.5	1_2904_003
	1 x	Spare blade	2_4201_004
	1 x	Plastic suitcase	1_2800_007/2

4_4200_031	Rotational Peeling Tool 20-125 mm		Enclosed
	1 x	Instruction manual	GB267
	1 x	Rotational Peeling Tool 20-125 mm	
	1 x	Hex key screwdriver SW4/SW2.5	1_2904_003
	1 x	Spare blade	2_4201_004
	1 x	Plastic suitcase	1_2800_007/2

4. Technical data

4.1 Rotational Peeling Tool 20-63 mm

4_4200_001		Rotational Peeling Tool 20-63 mm
General		
Suitable for pipes made of		PE, PE-HD, PE-X, PP
For pipe dimensions	[mm]	20 (min. SDR11) to 63 (max. SDR17.6)
Scraping depth	[mm]	0.2 (0.15 to 0.25)
Dimensions, weights and packaging		
Product dimensions L x W x H	[mm]	190 x 100 x 70
Product weight	[kg]	0.8
Packaging dimensions L x W x H	[mm]	275 x 230 x 85
Packaging material		Plastic
Packaging type		Suitcase
Packaging weight	[kg]	0.5
Transport weight	[kg]	1.3

The given technical information is valid for the standard setup of the tool. Depending on the ordered setup there may be variations.

4.2 Rotational Peeling Tool 20-125 mm

4_4200_031		Rotational Peeling Tool 20-125 mm
General		
Suitable for pipes made of		PE, PE-HD, PE-X, PP
For pipe dimensions	[mm]	20 (min. SDR11) to 125 (max. SDR17.6)
Scraping depth	[mm]	0.2 (0.15 to 0.25)
Dimensions, weights and packaging		
Product dimensions L x W x H	[mm]	260 x 60 x 170
Product weight	[kg]	1.1
Packaging dimensions L x W x H	[mm]	275 x 230 x 85
Packaging material		Plastic
Packaging type		Suitcase
Packaging weight	[kg]	0.5
Transport weight	[kg]	1.6

The given technical information is valid for the standard setup of the tool. Depending on the ordered setup there may be variations.

5. Spare parts

5.1 Rotational Peeling Tool 20-63 mm

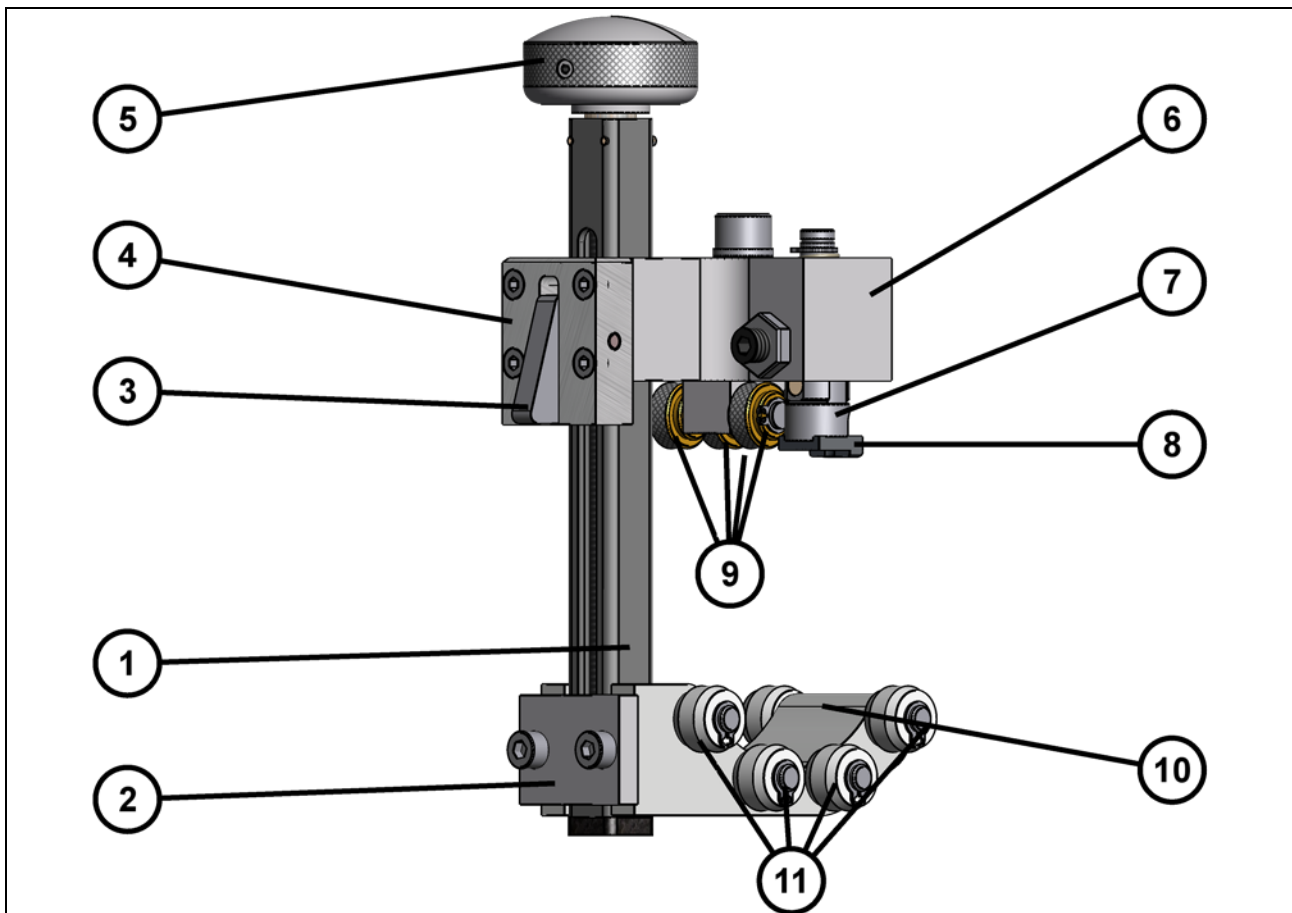

Object in graphic	Description	Code
1	Spindle w/supporting bar (with adjustmend knob)	2_2502_001/2
2	Connection plate for running shell	2_2502_017/1
3	Quick adjusting catch incl. spring	2_2502_008
4	Catch holder	2_2502_016
5	Adjustment knob	1_2400_008/2
6	Aluminium block with blade holder	2_2502_014
7	Bladeholder	2_2502_021
8	Spare blade (black container)	2_4201_004
9	Brass feeding wheel	1_2502_009
10	Running shell	1_2502_015
11	Running wheel (incl. securing ring)	2_2502_005

5.2 Rotational Peeling Tool 20-125 mm

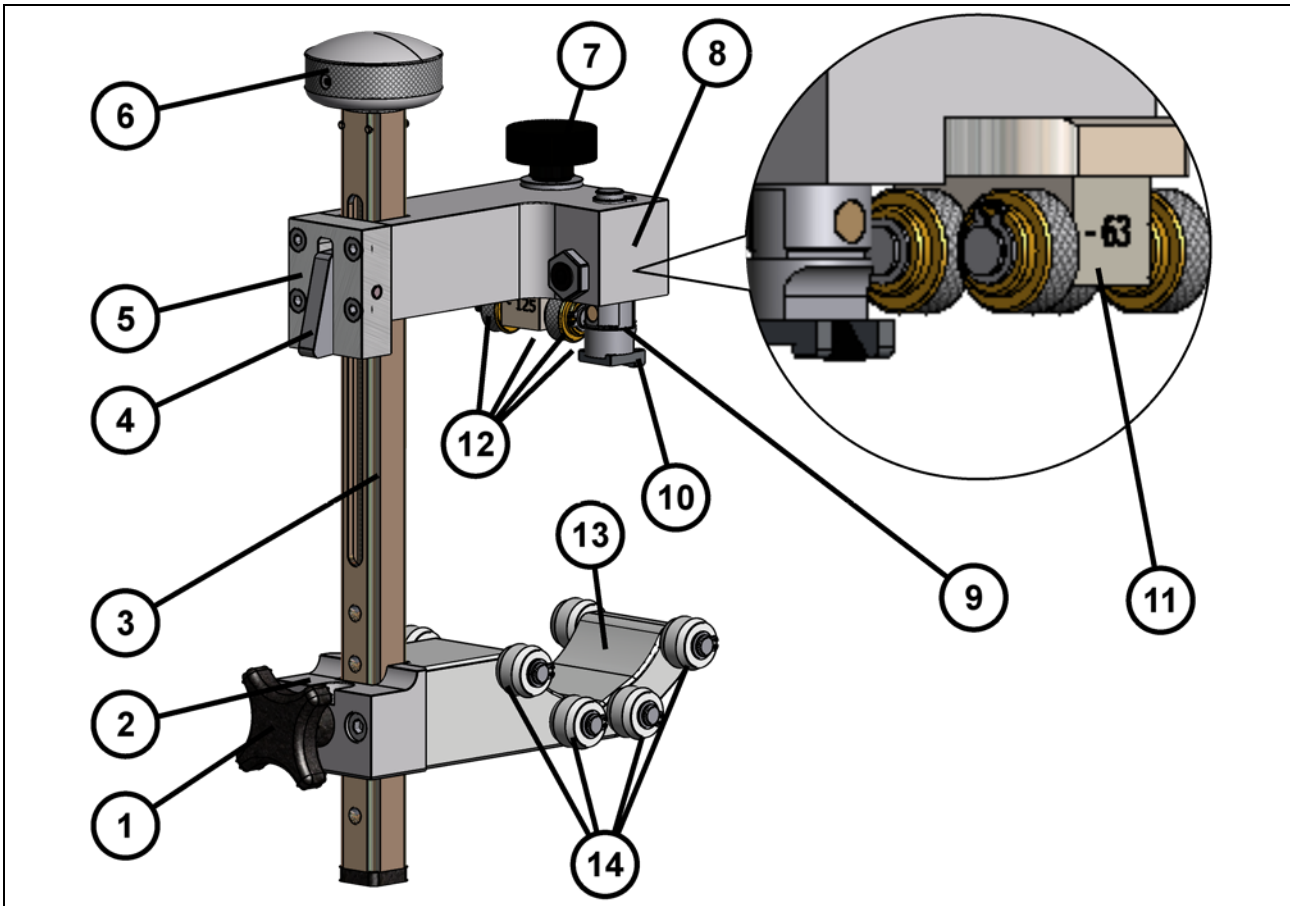

Object in graphic	Description	Code
1	Cross handle	1_2400_027
2	Connection plate for running shell	2_2502_017
3	Spindle w/supporting bar (with adjustmend knob)	2_2502_001
4	Quick adjusting catch incl. spring	2_2502_008
5	Catch holder	1_2502_016
6	Adjustment knob	1_2400_008/2
7	Knurled knob	1_2400_035
8	Aluminium block with blade holder	2_2502_070
9	Bladeholder	2_2502_021
10	Spare blade (black container)	2_4201_004
11	Feeding block complete	2_2502_076
12	Brass feeding wheel	1_2502_009
13	Running shell	1_2502_071
14	Running wheel (incl. securing ring)	2_2502_005

6. Overview

6.1 Rotational Peeling Tool 20-63 mm

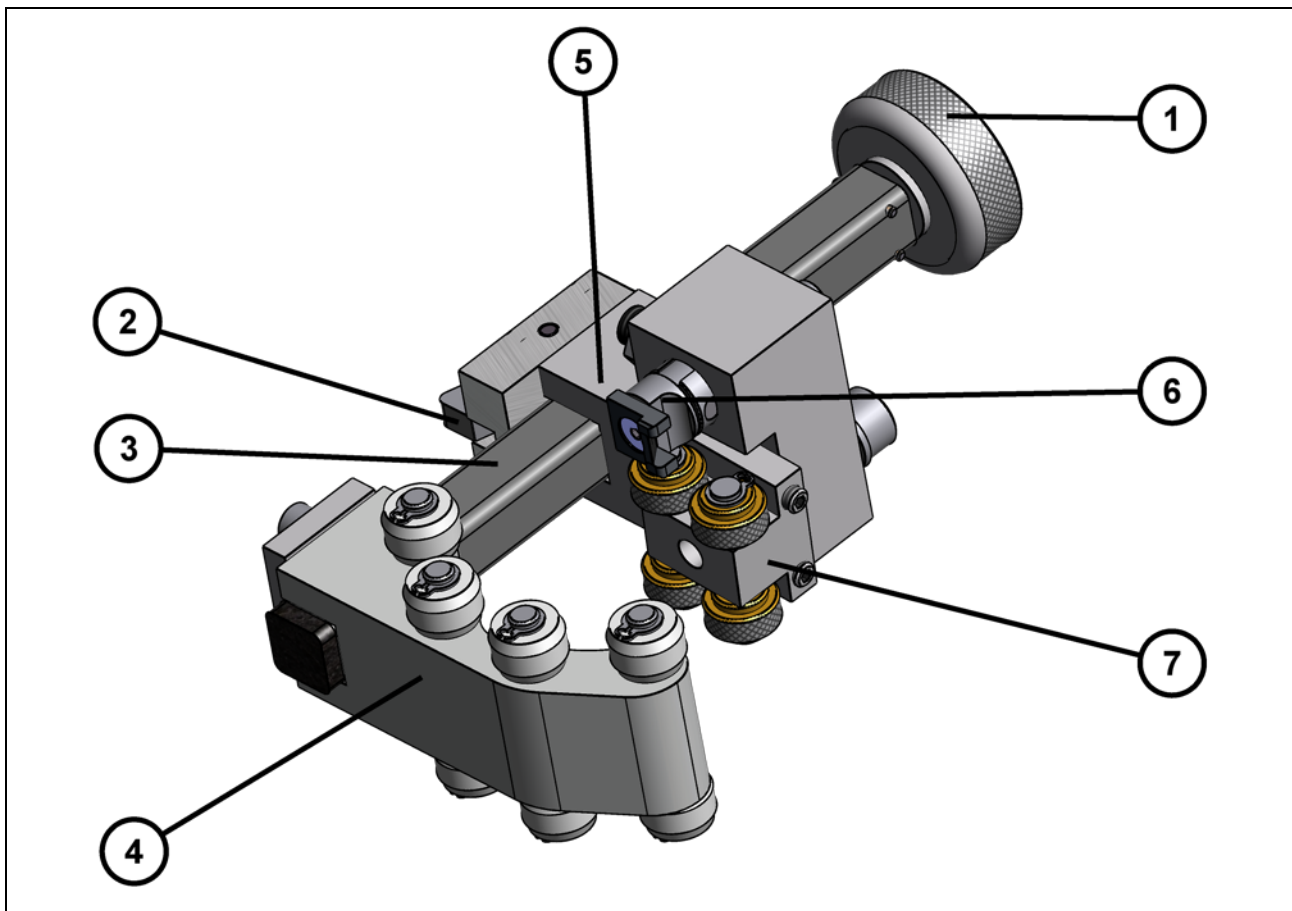

Object in graphic	Description
1	Adjustment knob
2	Quick adjustment catch
3	Support bar
4	Running shell with running wheels
5	Aluminium block for blade holder
6	Blade holder with peeler blade
7	Feeding block

6.2 Rotational Peeling Tool 20-125 mm

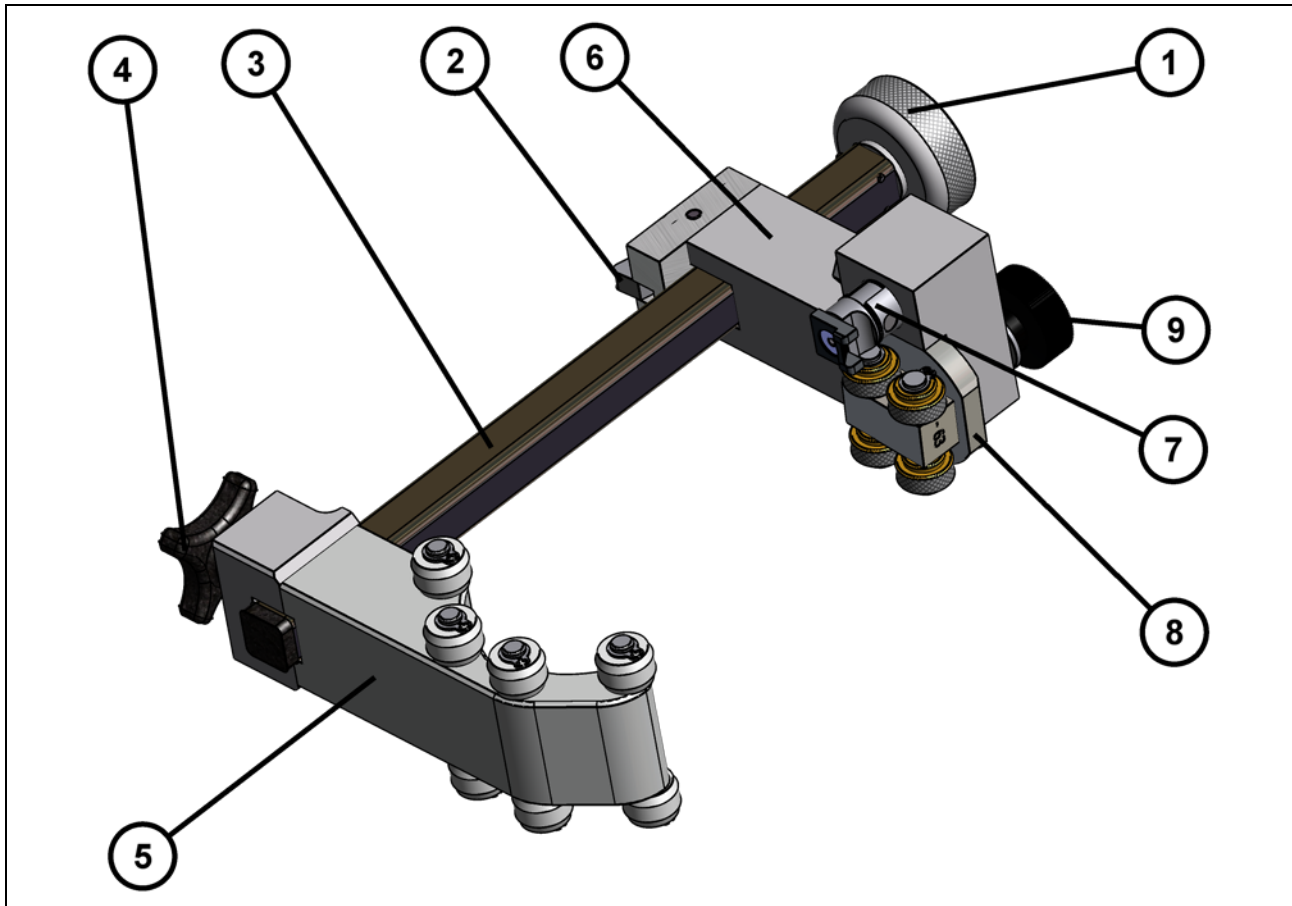

Object in graphic	Description
1	Adjustment knob
2	Quick adjustment catch
3	Support bar
4	Cross handle
5	Running shell with running wheels
6	Aluminium block for blade holder
7	Blade holder with peeler blade
8	Feeding block
9	Knurled knob

6.3 Special features

- Quick tensioning and adjustment to various pipe dimensions by quick adjustment features*.
- Secure guidance of the peeling tool as well as an even chip removal on oval pipes due to ovality compensation*.
- Tilttable blade as well as tilttable blade wagon for optimum guidance of the peeler blade on uneven or dented pipe surfaces.

*Patented features of the rotational peeler tool made by PF-Schweißtechnologie GmbH

7. Scraping

Due to the patented features of the tool, like the quick adjustment, the ovality compensation and the tiltable blade, an easy adjusting and installation of the tool on various pipe dimensions as well as an even chip removal on pipes with ovalities or conical ends can be easily performed.



Note

The numbers in brackets refer to the respective overview in chapter 6 "Overview and spare parts". The following procedure for peeling with the rotational peeling tool is valid for both versions (20-63 mm and 20-125 mm). If there are any specialties, they will be mentioned separately.

7.1 Preparation

Step	Action
1	Cleaning the pipe
1.1	Use a clean cloth free of dirt and grease to remove mud, sand and dirt from the surface you want to peel. If necessary additionally use certified pipe cleaner.
2	Mark the area you want to peel
2.1	Mark the insertion depth of the fitting resp. the area of contact of the saddle according to the processing guidelines of the fitting manufacturer with a certified marker. The area to be peeled should be marked with wave-like markings.

7.2 Preparation and adjustment

To prevent the rotational peeling tool from unintentionally losing its tensioning force while peeling, the supporting bar has a row of counterbores. Before beginning to use rotational peeler tool on a pipe it must be properly adjusted to the required pipe dimension.

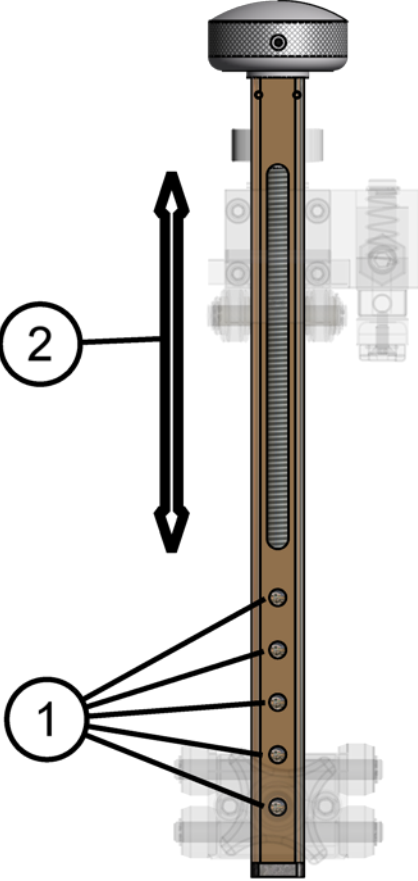
Step	Action
1 1.1	<p data-bbox="272 398 488 427">Overview picture</p> <p data-bbox="272 450 1437 539">The following picture shows an overview of the settings of the Rotational Peeling Tool 20-125 mm. The areas marked with 1 indicate the counterbores on the supporting bar. The areas marked with 2 show the range in which the attached running shell can be adjusted (quick adjustment).</p> 

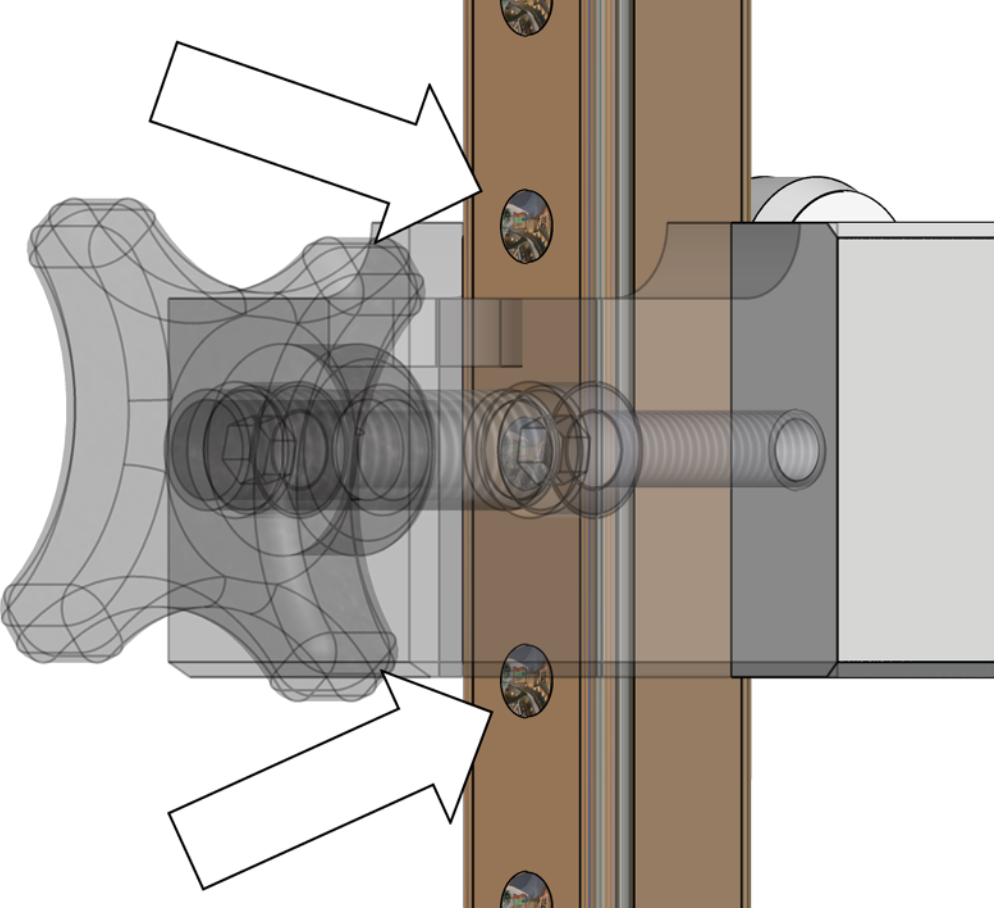
Step	Action
2	Centering
2.1	To properly adjust the rotational peeling tool, the running shell with the black cross handle must be positioned accordingly and locked in place.
	
2.2	The set screw is exactly centered above a counterbore when half of both of the adjacent counterbores are visible. In the following chapters there will be indications which pipe dimension can be peeled with what setting.

7.2.1 Rotational Peeling Tool 20-125 mm

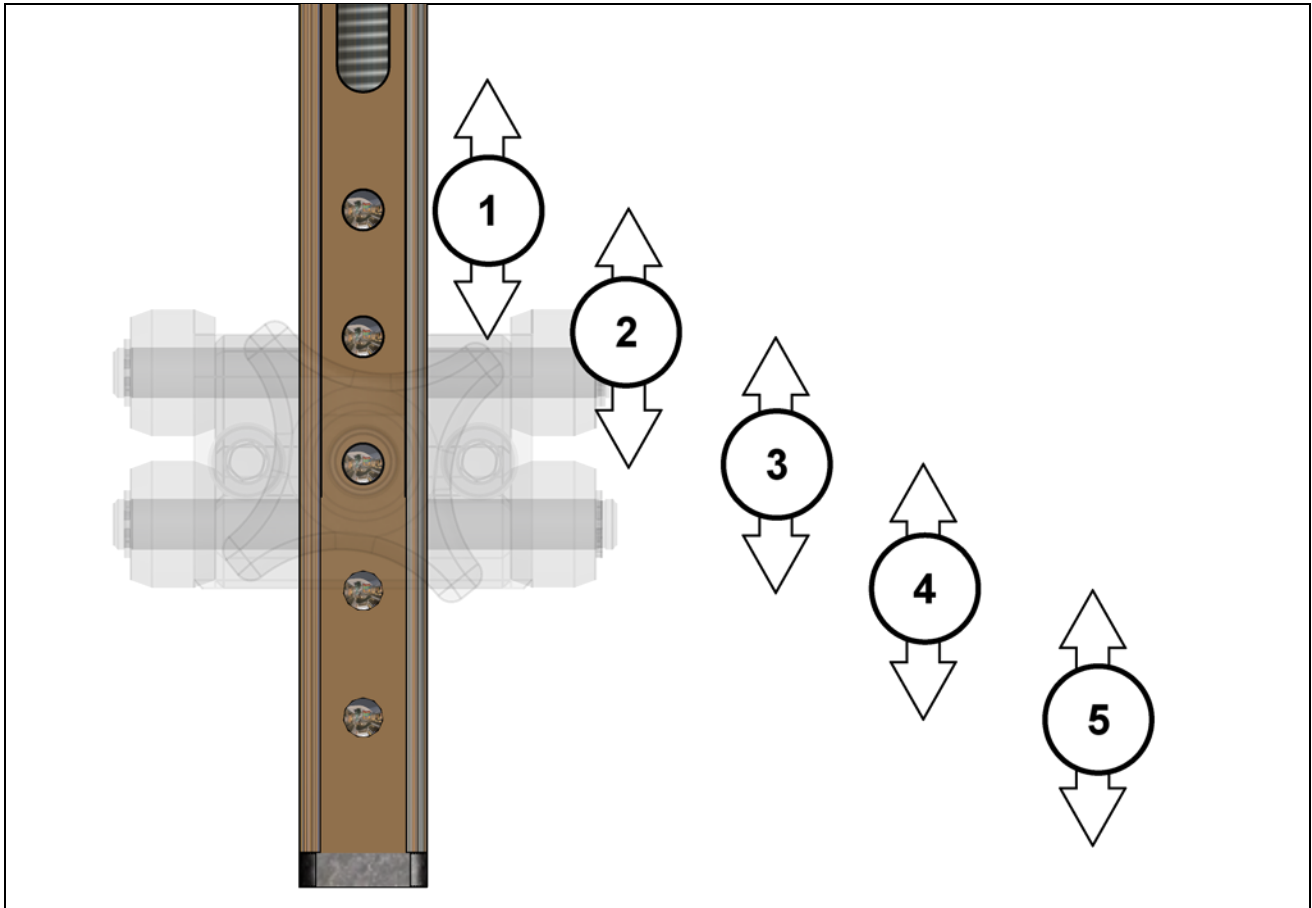

Setting	Suitable for dimension
1	20, 25, 32, 40 mm
2	50, 63 mm
3	50, 63, 75 mm
4	75, 90 mm
5	110, 125 mm

7.3 Peeler blade adjustment



Adjustment of the peeler blade before tensioning on the pipe

The design of the Rotational Peeling Tool 20-125 mm makes it necessary to adjust the feed setting before mounting it on the pipe. There are only two settings that cover the whole dimension range. Note that you have set the correct dimension range setting before beginning the scraping procedure.



NO STEP IN THE ADJUSTMENT PROCEDURES REQUIRES MAJOR FORCE!

The adjustment of the peeler blade **MUST** be done carefully and slowly. There must not be any major force involved.

The Rotational Peeling Tools are precision instruments.

Proceed carefully and slowly. If you notice that something gets stuck or does not work as expected, first find solve the issue before using more force than necessary.

Should the feeding block not sit correctly in place and it is tightened despite being not being adjusted properly, the tool can be severely damaged.

Make sure that the tool is clean. Dirt and sand can lead to the mechanics getting stuck.

Any excessive use of force or failure to comply to the described steps and notes/precautions for the adjustment of the peeler blade resp. feed is considered as improper use.

The manufacturer is not liable for use of the Rotational Peeling Tool that falls outside its application scope!

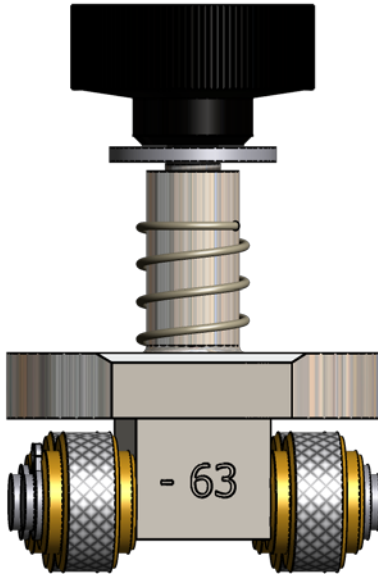
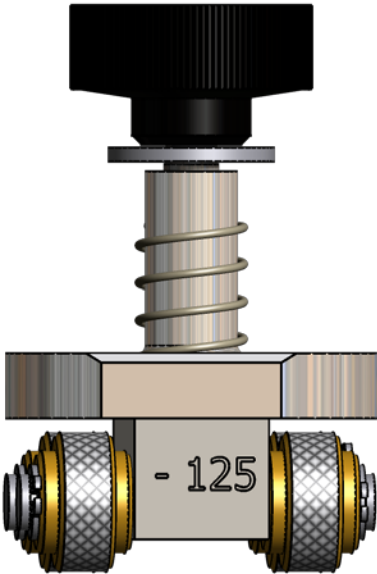
Step	Action
1	Understanding the settings
1.1	<p>The following pictures show, what both possible settings for the feed of the peeler blade and the numbers pointing towards you, when looking at the front of the tool, mean.</p> <div style="display: flex; justify-content: space-around; align-items: center;"> <div style="text-align: center;">  <p>Setting for the dimension range 20-63 mm</p> </div> <div style="text-align: center;">  <p>Setting for the dimension range 75-125 mm</p> </div> </div>
1.2	The following steps describe the adjustment.

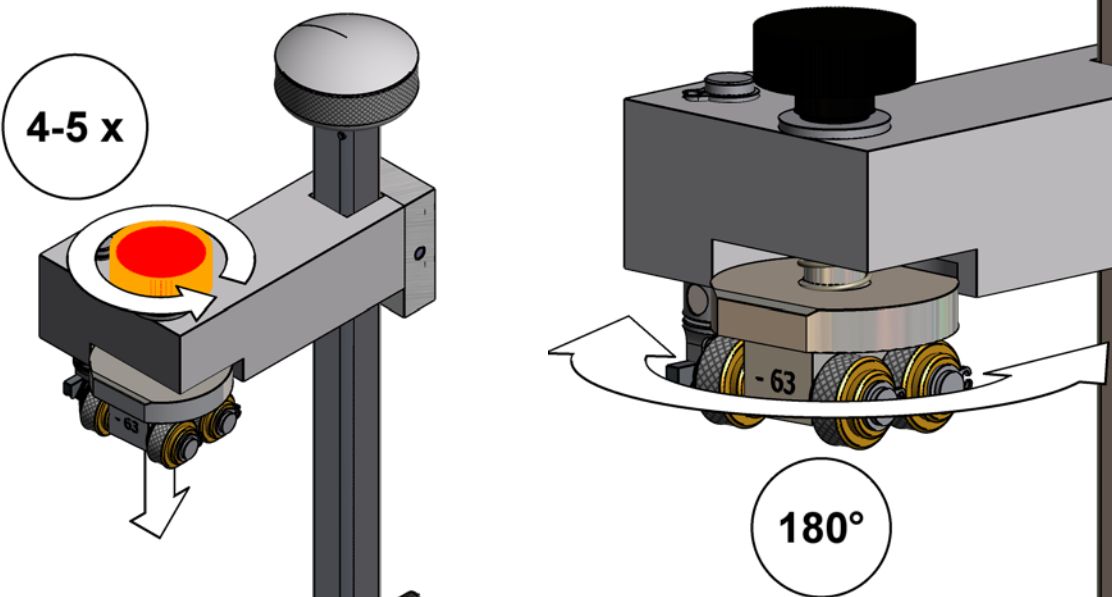
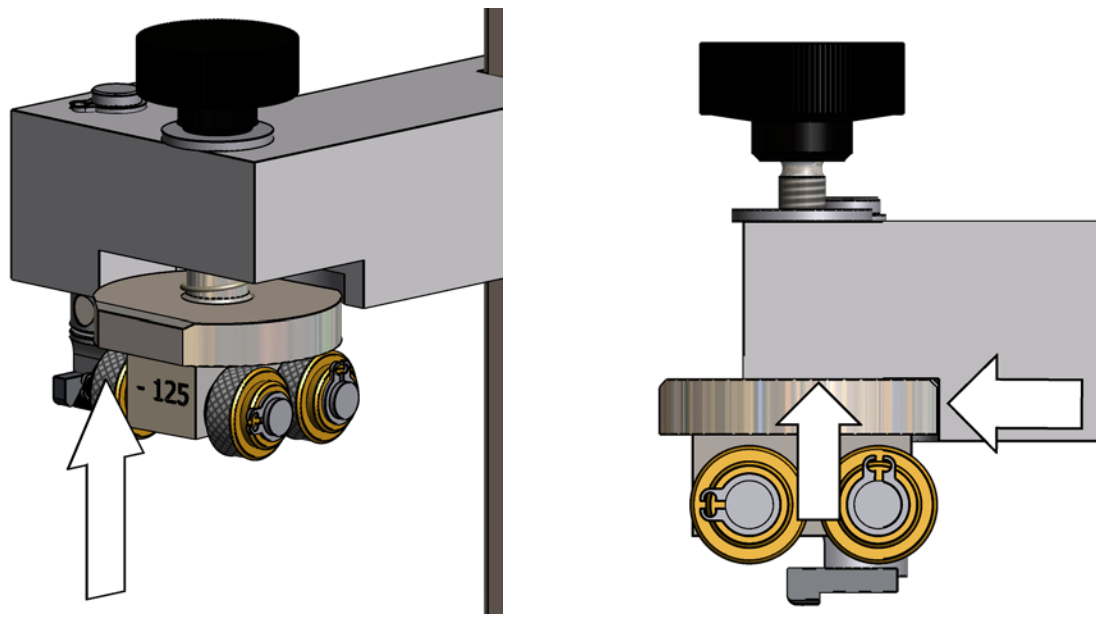
Step	Action
2	Setting the dimension range
2.1	Turn the knurled knob approx. 4-5 Turns counterclockwise. The feeding block will come loose and turnable.
2.2	Make sure that you can freely turn the feeding block. If this is not the case, turn the knurled knob counterclockwise until the feeding block can be turned freely without blocking.
2.3	Turn the feeding block 180° so that the opposite number, either "-63" or "-125" points towards you.
	
2.2	Then carefully press the feeding block upwards. If you have correctly turned and adjusted the feeding block, you will be able to press it completely against the upper running shell and it will rest fully against it with its flat side.
	



NEVER press the feeding block forcefully upwards against resistance and never tighten it unless it rests completely against the upper running shell.

Failure to comply with these preconditions will result in damage to the Rotational peeling tool.

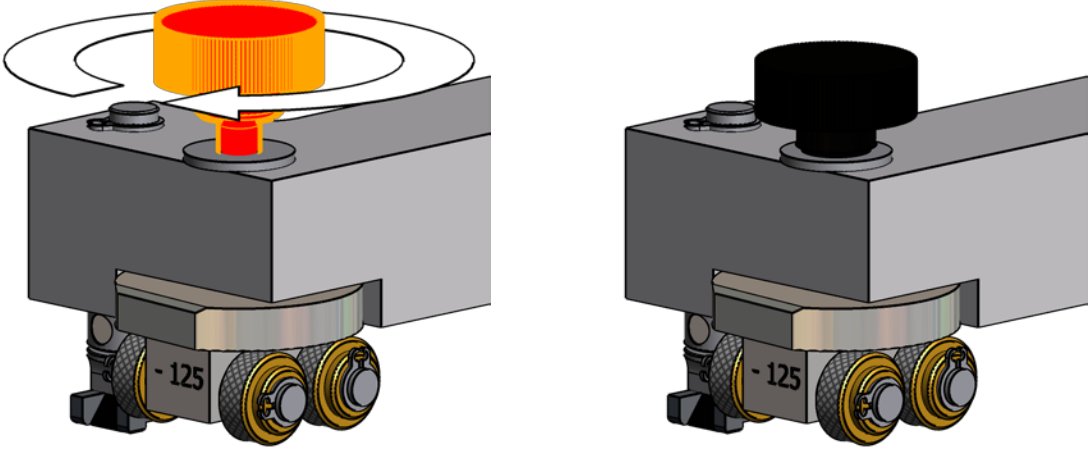
Step	Action
2.3	<p data-bbox="268 206 798 235">Turn the knurled knob clockwise to tighten it.</p> 
2.4	<p data-bbox="268 913 853 943">This concludes the adjustment for the dimension.</p>

7.4 Mounting the Rotational Peeling Tool



Attention!

For the Rotational Peeling Tool 25-63 mm an adjustment of the lower running shell is **NOT NECESSARY**.

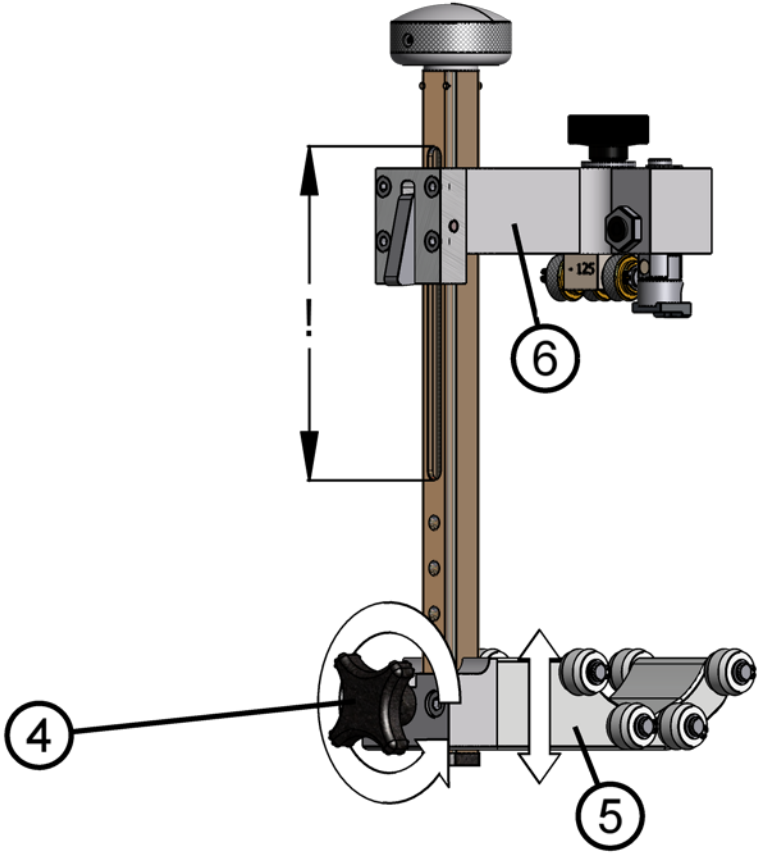
Step	Action
1	<p>Preparation of the Rotational Peeling Tool</p>
1.1	<p>To peel pipes on the lower end of the tool's dimension range (32 mm, 40 mm) it can be necessary, (only for the Rotational Peeling Tool 20-125 mm), to move the running shell with running wheels (5) on the spindle because otherwise the peeler blade on the upper part of the tool might not come into contact with the pipe surface. For adjustment loosen the cross handle (4).</p> <p>After that move the running shell with wheels (5) to a position that is suitable for the pipe dimension you want to peel. Use the counterbores when tightening the screw to be able to securely hold the running shell in place. Rule of thumb: The smaller the pipe dimension, the more you need to move the lower running shell upwards on the rail.</p> <p>After that tighten the lower cross handle (4) again.</p> 



Note

The aluminium block with the blade holder (6) can only be moved so far down until it reaches the end of the visible threaded rod.

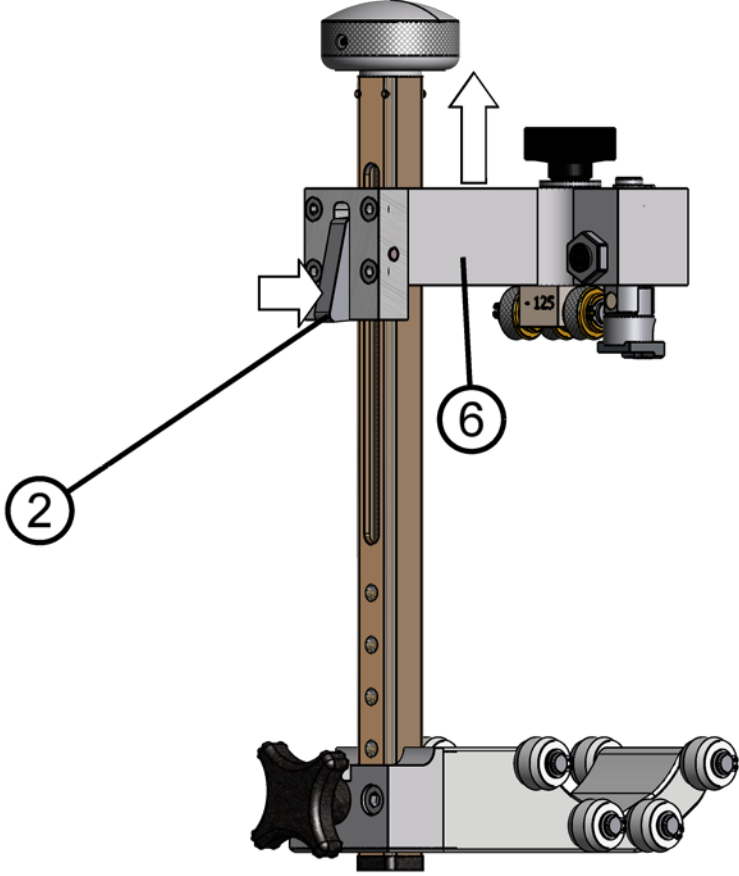
Step	Action
2 2.1	<p data-bbox="272 219 722 253">Applying the rotational peeling tool</p> <p data-bbox="272 271 1406 331">Actuate the quick adjustment catch (2) and bring the aluminium block with blade holder (6) in its upper position.</p>  <p>The diagram shows a vertical mechanical assembly. At the top is a cylindrical cap. Below it is a vertical shaft with several holes. A horizontal aluminium block with a blade holder is mounted on the shaft. A quick adjustment catch (2) is located on the left side of the block, with a white arrow pointing to it. A callout (6) points to the aluminium block. A white arrow points upwards from the top of the block, indicating its movement. The base of the assembly consists of a horizontal block with four rollers and a black handle on the left.</p>

Step	Action
<p data-bbox="188 219 212 253">3</p> <p data-bbox="177 271 220 304">3.1</p>	<p data-bbox="268 219 1241 253">Insert a pipe and press the upper part of the rotational peeling tool against it</p> <p data-bbox="268 271 1430 331">Position the tool on the pipe so that either at least the inner pair of rollers (for smaller pipes) or the outer pair of rollers (for larger pipes) have good contact to the pipe surface.</p> <div data-bbox="279 369 1436 1075"> </div>
<p data-bbox="177 1178 220 1211">3.2</p>	<p data-bbox="268 1167 1420 1227">Then press the upper part down so that the peeler blade and the brass wheels of the feed wagon touch the pipe surface. Do not press further down yet.</p>

7.4.1 Further course of action for the scraping of pipe ends

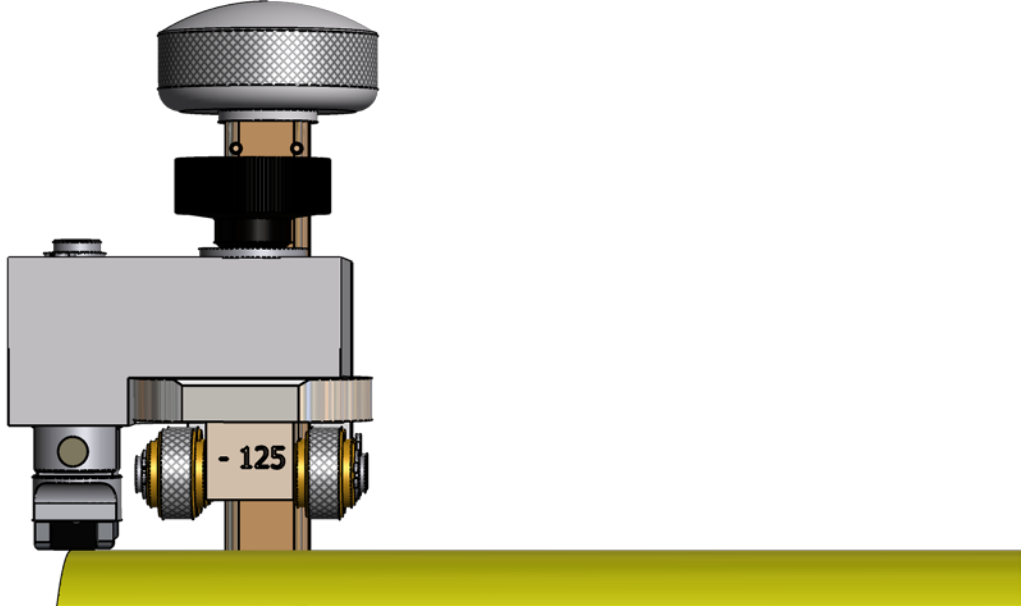
Step	Action
4 4.1	<p data-bbox="272 271 788 300">Installation for the scraping of pipe ends</p> <p data-bbox="272 322 1326 383">Position the rotational peeling tool so that between about 1/2 and 2/3 of the peeler blade, depending of the pipe dimension and feed setting, rest on the pipe.</p>  <p>The diagram shows a rotational peeling tool with a grey body and a black adjustment knob on top. A cylindrical component with a textured surface is marked with '- 125'. The tool is positioned against a yellow pipe end, with the peeling blade resting on the surface.</p>

7.4.2 Further course of action for the scraping of saddle installation areas

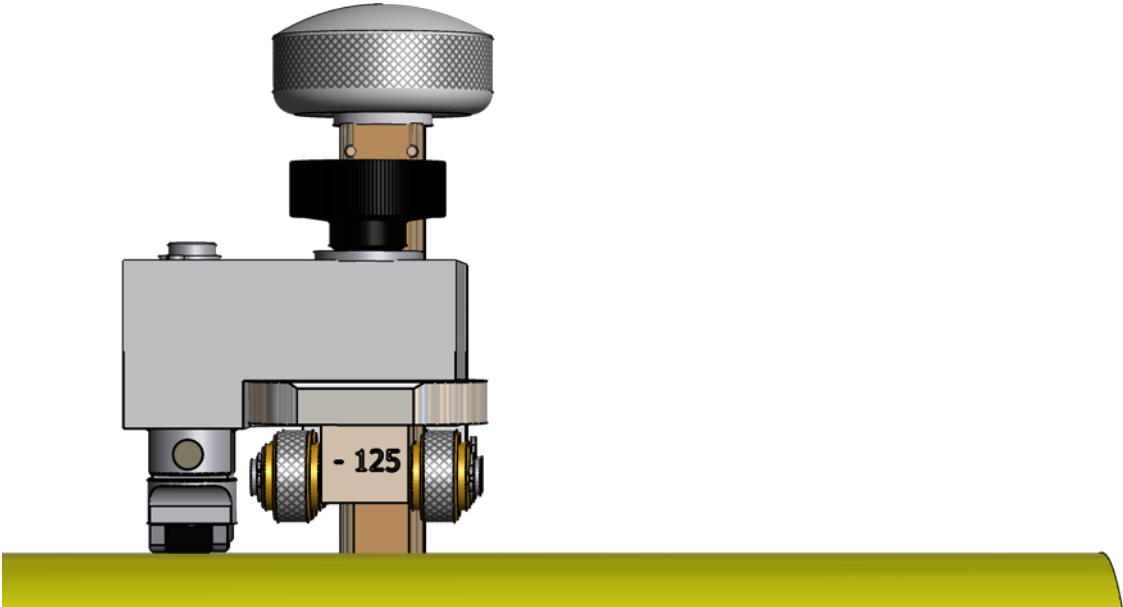
Step	Action
4 4.1	<p data-bbox="272 1211 826 1240">Installation for the scraping of saddle areas</p> <p data-bbox="272 1263 1433 1323">Position the rotational peeling tool on the desired location on the pipe. The blade should be set on the middle of the outer limit of the marking on the area of contact.</p>  <p>The diagram shows the same rotational peeling tool as in 7.4.1, but it is positioned against a yellow pipe saddle area. The peeling blade is set on the middle of the outer limit of the marking on the area of contact.</p>

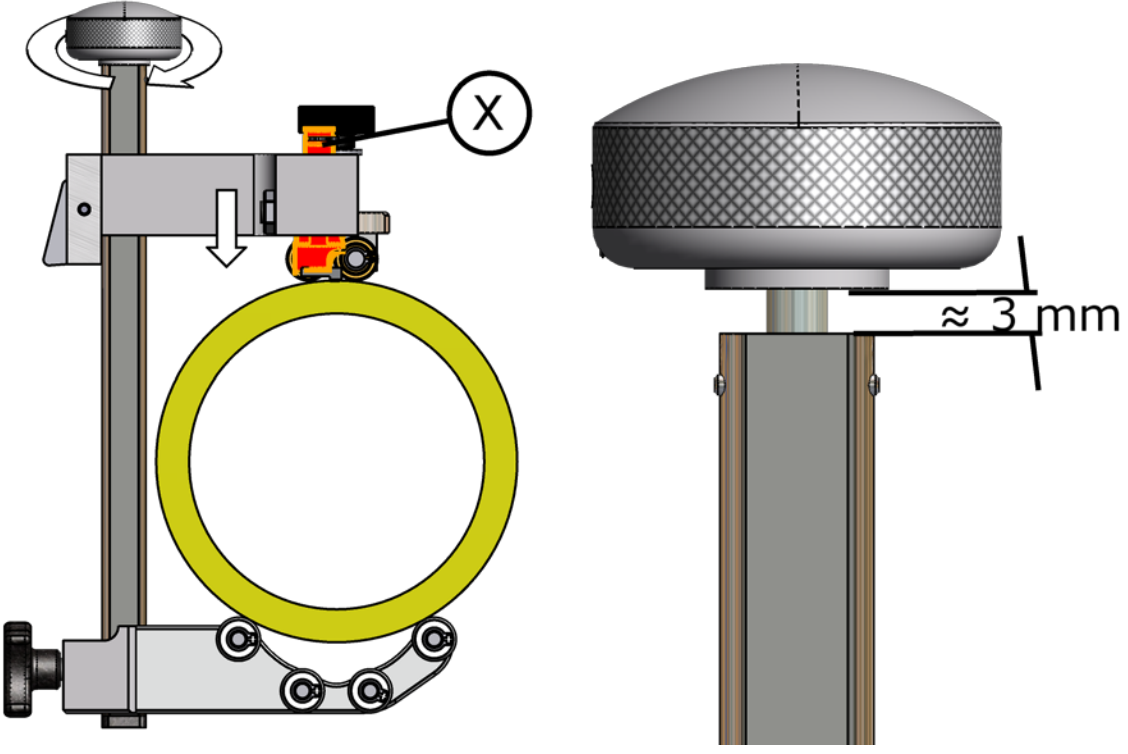
Step	Action
<p>5</p> <p>Tensioning the Rotational Peeling Tool</p> <p>5.1 By turning the adjustment knob the pipe will be clamped between the running wheels of the lower part and the feeding wheels of the upper part. The peeler blade is now pressed, against spring pressure, onto the pipe surface.</p> <p>5.2 Turn the adjustment knob clockwise to the extent that it is lifted about 3 mm and note that the tension force indicator (X) is also lifted. This tension compensates for a possible ovality in the pipe and ensures that the peeler blade is pressed firmly against the pipe surface. The running wheels now have contact to the pipe without deforming it.</p>	



Attention!

If you are turning the adjustment knob too many times you could damage the peeling tool.

7.5 Scraping the pipe

Step	Action
1	Clamping and fixing the pipe
1.1	Fix or clamp the pipe before you begin scraping it to improve the scraping result and prevent accidents.
2	Finding the correct posture to peel
2.1	Position yourself so that the cutting edge of the peeler blade of the mounted tool faces towards you.
2.2	Your position should ideally be 90° to the pipe so that no axial forces influence the set feed of the tool.
3	Scraping procedure
3.1	Grip the peeling tool by the adjustment knob and pull it straight towards you.
3.2	Watch how the chip is removed. If the peel width is maximum 2/3 of the blade width continue moving the rotational peeling tool around the pipe until you have peeled the desired area of the pipe surface.



Note

If the peel is wider than 2/3 of the blade width check if you work with the correct dimension setting for the feed.

7.6 Taking the rotational peeling tool off

Step	Action
1	Reduce tensioning
1.1	To remove the rotational peeling tool from the pipe first reduce the mounting force to the pipe by turning the adjusting knob counter-clockwise.
1.2	As soon as the mounting force is reduced you can open the rotational peeling tool by pressing the quick release catch (2) and take it off.



Note

After removing the tool from the pipe always make sure that you have completely peeled the desired area.

When using the Rotational Peeling Tool on pipes of varying sizes you must make sure each time that you work with the correct dimension setting for the feed.

7.7 Additional notes

- In case of an insufficient scraping result the blade has to be replaced.
- In consideration of the processing guidelines of the fitting manufacturer and the tolerances specified therein (max. gap between pipe and fitting) the pipe may be peeled a second time.
- The peeler blades are subject to wear
- Use only on cleaned pipe surfaces.
- Keep the rotational peeling tool clean and dry in the suitcase.
- The thickness of the peeling must be checked with a suitable measuring instrument on a regular basis.

8. Changing the peeler blade



Attention!

The blade is very sharp! Handling the spare blades involves a high risk of injury. Always wear cut-proof gloves as soon as you handle the scraping blades.

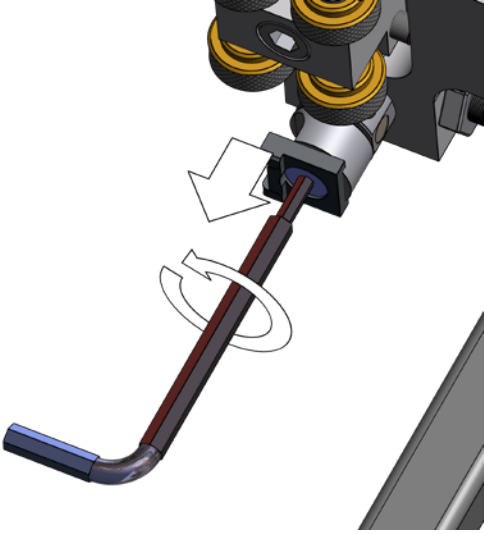
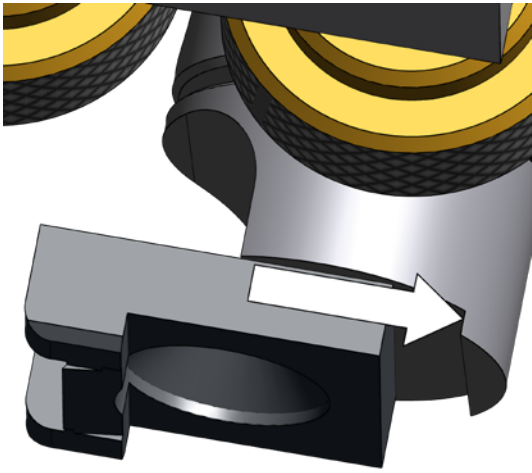
Step	Action
1 1.1	<p data-bbox="272 477 496 510">Loosen the screw</p> <p data-bbox="272 528 1366 589">Loosen the hexagon socket head screw (2.5 mm) that secures the peeler blade on the blade holder with the enclosed key and remove the old peeler blade.</p> 
2 2.1	<p data-bbox="272 1211 576 1245">Mount new peeler blade</p> <p data-bbox="272 1263 1398 1323">Make sure that the peeler blade lies flat on the blade holder and that it touches the stop with its backside.</p> 

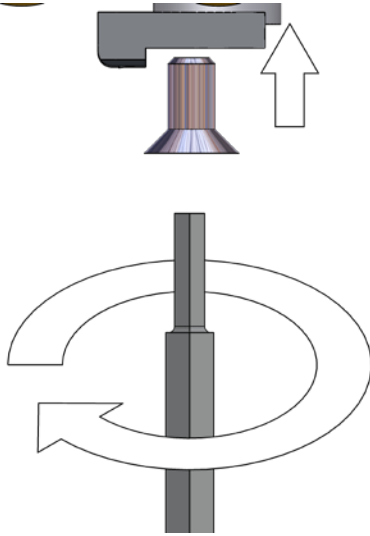
Step	Action
<p data-bbox="177 215 209 241">3</p> <p data-bbox="177 266 220 293">3.1</p>	<p data-bbox="268 215 580 241">Fix the new peeler blade</p> <p data-bbox="268 266 1437 327">Hold the peeler blade in this position and screw the hexagon socket head screw (2.5 mm) in again with the enclosed key.</p> 



Note

The spare blades are incompatible with the pipe end peelers of PF-Schweisstechnologie GmbH, because these have a different edge.



General

Read complete manual!
Observe fitting manufacturer's installation guide!
Follow national and international directives!

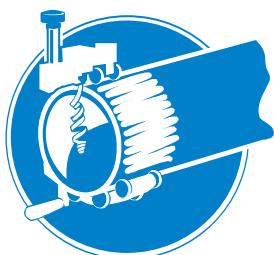

Scraping

Remove dirt from the pipe!
Mark welding area!
Use rotational scraper tools only!



Cleaning

Wipe around the pipe!
Use approved cleaning agent!
Use lint-free cloths!

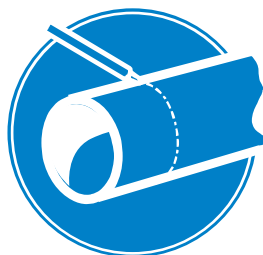

Marking

Do not touch the cleaned welding areas!
Mark insertion depth of fitting!
Use approved markers!

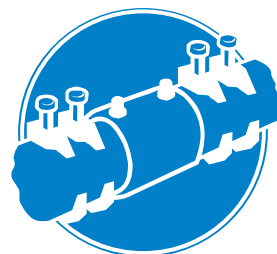

Alignment

Use proper alignment tools!
Avoid mechanical stress on pipes and fitting!
Wait for cooling before pressurising!

PF-Schweißtechnologie GmbH

Karl-Bröger-Straße 10

DE-36304 Alsfeld/Germany

Phone +49 6631 9652-0

E-Mail: info@pfs-gmbh.com

www.pfs-gmbh.com